

PHILIPS RADIOPLAYER

MODEL 125

SPECIFICATIONS

(Subject to alteration without notice)

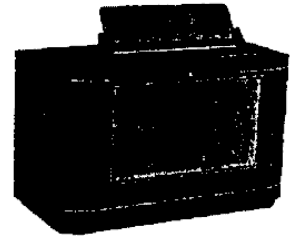

Power Supply	220-260V, 40-60 c/s.
Tuning Ranges	530-1620 kc/s. 5.9-18.4 Mc/s.
Magnified S/W Ranges	9.4-10.0 Mc/s (31M band) 11.4-12.1 Mc/s (25M band) 15.0-15.7 Mc/s (19M band) 17.4-18.0 Mc/s (16M band)
Intermediate Frequency	455 kc/s.
Cabinet	Wooden table

VALVE EQUIPMENT AND VOLTAGE ANALYSIS

Valve Function	Valve No.	Valve Type	Plate Volts	Screen Volts	Osc. P. Volts
R.F. Amplifier	V1	6N8	252	49	—
Frequency Converter	V2	6AN7	252	92	99
I.F. Amplifier, A.V.C. and Demodulator	V3	6N8	252	75	—
Audio Amplifier	V4	6N8	41	12	—
Power Amplifier	V5	6M5	235	252	—
Rectifier	V6	6X5GT	V6 Cathode to L14 C.T. — 308V.		
Dial Lamps	V11 & V12	6.3V 0.32A tubular screw			

Voltage across R6, -3.2V; across R5 and 6, -7.9V.

NOTE: These voltages are measured with an "1,000 ohms per volt" meter and may vary \pm 10% from the figures quoted. They are measured from the socket points indicated to chassis or across the resistors listed. The receiver should be in a "no signal" condition.

TO REMOVE CHASSIS FROM CABINET.

Remove the power plug from the mains outlet socket. Remove the cabinet back and the four control knobs (a firm pull is all that is necessary). Release the dial cursor assembly from the dial cord and withdraw the dial lamps plug from its socket. The chassis is held to the cabinet by means of four screws in the base of the chassis and three in the baffle. Removal of these screws permits the chassis to be withdrawn from the cabinet. As the chassis is withdrawn, it should be tilted to prevent the baffle fouling the dial assembly.

The chassis may be refitted to the cabinet by a reversal of the above procedure.

MAINS VOLTAGE ADJUSTMENT.

The power transformer is provided with two primary winding tappings—220/240 volts and 250/260 volts—for adjustment of the receiver to the supply voltage at the point of installation. The receiver is adjusted at the factory to the 220/240 volts tapping.

DIAL CALIBRATION ADJUSTMENT.

If station calibrations are incorrect by an equal amount over the length of the dial scale, the condition may be corrected by loosening the cursor to dial cord clamping screw, making the necessary adjustment, and firmly retightening the screw.

ALIGNMENT.

The incorporation of a removable cabinet bottom cover allows nearly all of the alignment work to be performed without having to remove the chassis from the cabinet. It is, however, necessary to remove the chassis for adjustment of the aerial trimmers for the continuous short wave and both magnified bands. Before commencing alignment, set the dial cursor, with the tuning capacitor fully closed, to the 300 mark on the escalator scale.

A diagram showing the location of the trimming capacitors is published with the circuit diagram drawing. The B/C aerial trimmer (not shown on the drawing) is mounted on top of the chassis.

The iron cores for the secondaries of the I.F. transformers are accessible from the top of the cans; those for the primaries are accessible from the bottom.

There is an interdependence between trimmers and it is necessary that the broadcast and continuous short wave bands be completely aligned before alignment of the magnified bands is attempted.

Alignment frequencies are:—

Broadcast band	1,420 kc/s. and 600 kc/s.
Continuous S/W band	18.4 Mc/s., 17.8 Mc/s., 6 Mc/s.
Magnified band I	11.9 Mc/s.
Magnified band II	15.3 Mc/s., 17.8 Mc/s.

Capacitive trimmer adjustments are used on all frequencies except 600 kc/s., where the B/C oscillator iron core is used, and 6 Mc/s., where the S/W oscillator iron core is used. Do not attempt to adjust the iron core of the aerial and R.F. coils.

In trimming magnified band II, use the series trimmer C34 at 15.3 Mc/s and the parallel trimmer C41 at 17.8 Mc/s. The procedure here, if calibrations do not come correct at the first attempt, is to halve out the error each time until calibrations are correct.

The magnified band oscillator trimmers should not be finally adjusted until the chassis is refitted to the cabinet.

If an oscillator coil has been replaced, a preliminary adjustment of the iron core is necessary. This is done at 600 kc/s. for the broadcast coil and 6 Mc/s. for the short wave coil. The adjustment consists of setting the

dial cursor to the appropriate frequency and adjusting the iron core until a signal of that frequency is received.

The oscillator and signal frequency relationships are:—

Continuous S/W band: Oscillator frequency higher than signal.

Magnified band I:

31 metres band: Oscillator frequency higher than signal.

25 metres band: Oscillator frequency lower than signal.

Magnified band II:

19 metres band: Oscillator frequency higher than signal.

16 metres band: Oscillator frequency lower than signal.

REMOVAL OF INCLINATOR DIAL ASSEMBLY.

This operation can be carried out with the chassis in position in the cabinet, but it is facilitated if it is first removed—see "To Remove Chassis from Cabinet." In order to prevent possible damage to the dial glass, it is well to remove it also—see "Dial Glass Removal."

The inclinometer dial assembly is held in place by means of two mounting brackets located at the ends. Removal of these brackets, from within the cabinet, permits the assembly to be lifted clear of the cabinet. If the operation is performed with the chassis in position, make sure that the dial lamp plug is removed from its socket, and the dial cursor is released from the dial cord before proceeding.

DIAL GLASS REMOVAL.

Raise the dial glass into its maximum forward position. This allows access to the dial glass clamping screws in the dial assembly end housing. Loosen the clamping screws (it is not necessary that they be completely removed) and withdraw the dial glass from the assembly. When the dial glass is replaced, make sure that it is securely clamped.

DIAL LAMP REPLACEMENT.

This operation is carried out from outside the cabinet. The dial lamps are located, one at each end of the dial glass, in the end housing. The covers are a clip fit and are easily removed.

PARTS LISTS

CAPACITORS

No.	Description	Code No.
C1	150 pF mica	
C2, 13, 14, 18, 24, 25, 37, 42, 43	30 pF air trimmer	CZ.113.700
C3, 19	50 pF mica \pm 1 pF	CZ.064.110
C4, 20	120 pF mica \pm 1%	CZ.065.712
C5	65 pF mica \pm 1 pF	CZ.064.111
C6, 22	260 pF mica \pm 1%	CZ.065.711
C7, 8, 9	3 gang tuning	CZ.108.204
C10, 62	0.1 mF 200V paper	
C11, 26	0.001 mF mica	
C12, 23, 34, 41	8 pF air trimmer	CZ.113.500
C15, 27, 50, 55	0.01 mF 600V paper	
C16	30 pF mica	
C17	5 pF mica	
C21	60 pF mica \pm 1 pF	CZ.064.109
C28, 29, 53	100 pF mica	
C30	40 pF ceramic \pm 1 pF	CZ.096.403
C31	20 pF mica \pm 1 pF	CZ.064.101
C33	190 pF mica \pm 1%	CZ.065.716
C35	45 pF mica \pm 1 pF	CZ.064.108
C36	225 pF mica \pm 1%	CZ.065.715
C38	450 pF mica \pm 2%	CZ.066.117
C39	0.0045 mF mica \pm 10%	
C44, 45	24 mF 525V electrolytic	
C46, 47	Part of 1st I.F. transformer	
C48, 61	0.05 mF 200V paper	

CAPACITORS

No.	Description	Code No.
C49	20 pF mica	
C51, 52	Part of 2nd I.F. transformer	
C54	0.002 mF 600V paper	
C56	100 pF mica \pm 10%	
C58	0.005 mF 600V paper	
C59	0.05 mF 400V paper	
C60, 66	0.02 mF 400V paper	
C63	50 pF mica	
C64	200 pF mica	
C65	0.02 mF 600V paper	
C68	1 pF wire	

RESISTORS

No.	Description	Code No.
R1, 7, 14	1 megohm $\frac{1}{2}$ W carbon	
R2, 31	250,000 ohms $\frac{1}{2}$ W carbon	
R3	25,000 ohms 1W carbon 10%	
R4	20,000 ohms $\frac{1}{2}$ W carbon	
R5	75 ohms 1W W/W 10%	
R6	50 ohms 1W W/W 10%	
R8	30,000 ohms 1W carbon 10%	
R9	15,000 ohms 1W carbon 10%	
R10	30,000 ohms 1W carbon	
R11	25,000 ohms $\frac{1}{2}$ W carbon	
R12	100 ohms $\frac{1}{2}$ W carbon	
R13	100,000 ohms $\frac{1}{2}$ W carbon	
R15, 16, 18, 26, 30	0.5 megohm $\frac{1}{2}$ W carbon	
R17	150,000 ohms 1W carbon	
R19, 21, 29	50,000 ohms $\frac{1}{2}$ W carbon	
R20, 32	10,000 ohms $\frac{1}{2}$ W carbon	
R22	0.5 megohm tapped carbon potentiometer CZ.029.129	
R23, 25	2 megohms $\frac{1}{2}$ W carbon	
R24	2 megohms 1W carbon	
R27	250,000 ohms 1W carbon	
R28	100,000 ohms 1W carbon	
R33	250 ohms $\frac{1}{2}$ W W/W 10%	
R34	25 ohms $\frac{1}{2}$ W W/W 10%	
R35	100 ohms $\frac{1}{2}$ W carbon	

COILS

No.	Ohms	Description	Code No.	No.	Ohms	Description	Code No.
L1	23 }	B/C Aerial Coil		L13	45 }		
L2	2 }	(2 white spots)	CZ.323.008	L14	600 }	Power Transformer	CZ.344.217
L3	1 }	S/W Aerial Coil (1 red		L15	<0.5 }		
L4	<0.5 }	and 1 white spot)	CZ.323.009	L16	<0.5 }		
L5	45 }	B/C R.F. Coil		L17	520 }	Filter Choke	CZ.341.002
L6	2 }	(2 black spots)	CZ.323.225	L18	12 }		
L7	<0.5 }	S/W R.F. Coil		L19	12 }	1st I.F. Transformer	CZ.320.421
L8	<0.5 }	(2 yellow spots)	CZ.323.226	L20	12 }		
L9	1 }	B/C Oscillator Coil		L21	12 }	2nd I.F. Transformer	CZ.320.420
L10	3 }	(1 blue spot)	CZ.330.602	L22	350 }	Speaker Transformer	
L11	<0.5 }	S/W Oscillator Coil		L23	0.5 }	6,000 ohms	CZ.345.007
L12	<0.5 }	(1 white spot)	CZ.330.603	L24	1.5 }	Speaker	CZ.161.216

IMPORTANT! In ordering spare parts, quote **CODE NUMBER** of part and **MODEL NUMBER** of Receiver. In claiming free replacement under **GUARANTEE**, return defective part **PROMPTLY** and quote **MODEL** and **SERIAL NUMBER** of Receiver and **DATE OF PURCHASE**.

MISCELLANEOUS COMPONENTS

No. on Dial Layout Drawing	Description	Code No.	No. on Dial Layout Drawing	Description	Code No.
—	Assembly, baffle	CR.005.240	—	Clamp, incl. dial mounting	CS.235.205
—	Assembly, cabinet bottom cover	CR.572.042	—	Clip, coil can mounting	CS.235.831
—	Assembly, cursor	CR.480.614	—	Cloth, baffle	CE.081.82
—	Assembly, dial housing R.H.	CR.272.604	—	Cover, front (incl. dial)	CS.430.842
—	Assembly, dial housing L.H.	CR.272.605	—	Cover, rear (incl. dial)	CS.430.843
—	Assembly, inclinometer dial	CR.484.815	—	Cord, baffle	CE.085.40
—	Assembly, lamp cover R.H.	CR.272.401	5	Cord, dial drive	CS.361.830
—	Assembly, lamp cover L.H.	CR.272.400	1	Drum, dial	CS.360.007
—	Assembly, pressure plate R.H.	CR.391.206	—	Key, W/C clicker	CS.365.808
—	Assembly, pressure plate L.H.	CR.391.207	—	Knob, control	CS.432.616
—	Assembly, pulley spindle	CR.436.209	—	Mount, incl. dial	CS.235.830
7	Assembly, pulley spindle bracket (bottom of baffle)	CR.265.003	—	Plate, clamping (incl. dial)	CS.355.200
6	Assembly, pulley spindle bracket (top of baffle)	CR.265.002	—	Plate, friction (incl. dial)	CS.366.200
—	Assembly, terminal	CZ.376.200	—	Plate, spindle bearing	CS.400.207
8	Assembly, tuning spindle	CR.371.318	4	Plug, 2-pin polarised	CR.102.200
—	Assembly, T/C clicker	CR.450.032	—	Pulley, wooden	CS.360.201
—	Assembly, T/C switch	CZ.200.507	4	Ring, "C" (tuning spindle)	CS.281.802
—	Assembly, slider hinge	CR.432.200	3	Ring, dial cord	CS.281.807
—	Assembly, W/C clicker	CR.450.038	—	Rod, dial slide	CS.382.202
—	Assembly, W/C switch	CZ.203.501	—	Scale, dial	CS.412.327
—	Assembly, W/C sw. mounting bracket	CR.264.800	—	Socket, 2-pin polarised	CR.102.401
—	Back, cabinet	CS.462.099	—	Socket, oval	CZ.369.702
—	Badge, Philips	CS.436.414	—	Socket, octal	CZ.369.703
—	Bank, W/C switch (A4)	CZ.200.509	2	Spring, compression (incl. dial)	CS.281.806
—	Bank, W/C switch (A1-2)	CZ.200.508	—	Spring, dial drum	CS.210.010
—	Bank, W/C switch (A3)	CZ.200.510	—	Spring, return (incl. dial)	CS.212.201
—	Bank, T/C switch	CZ.200.512	—	Strip, masking	CS.050.403
—	Bracket, cover attaching R.H.	CS.229.803	—	Switch, mains on/off	CZ.220.001
—	Bracket, cover attaching L.H.	CS.229.802	—	Transfer, W/B indicator	CS.442.029
—			—	Transfer, T/C indicator	CS.442.028
—			—	Washer, felt (incl. dial)	CS.424.020
—			—	Washer, felt (knobs—thin)	CS.467.053
—			—	Washer, felt (knobs—thick)	CS.467.052

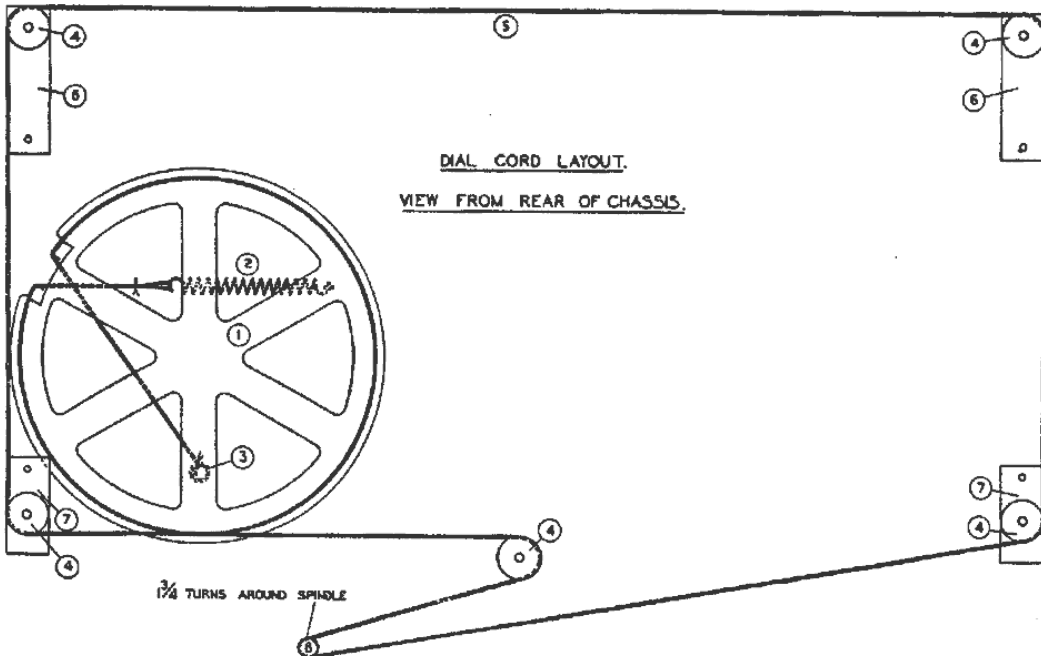

SERVICE DATA

1,3	2,4	7,8,8,8	13,14,15,15,15,15,15,15	16, 19	17
1	3, 4, 2, 5, 6	7, 11, 12, 10, 13, 14	15, 19, 16, 20, 17, 21, 22, 18	8, 23, 26, 24, 27, 25	28, 30, 29, 33, 34, 35, 29, 36, 37, 38, 39, 3
		4	5	9, 7, 35	6
				10, 11, 12	14
					11, 12, 5

SWITCH A1, A2, A3, A4 SHOWN IN BANDSPREAD 2. POSITION.
 POSITIONS: BANDSPREAD 2.
 BANDSPREAD 1.
 SHORT WAVE.
 BROADCAST.
 GRAMO.

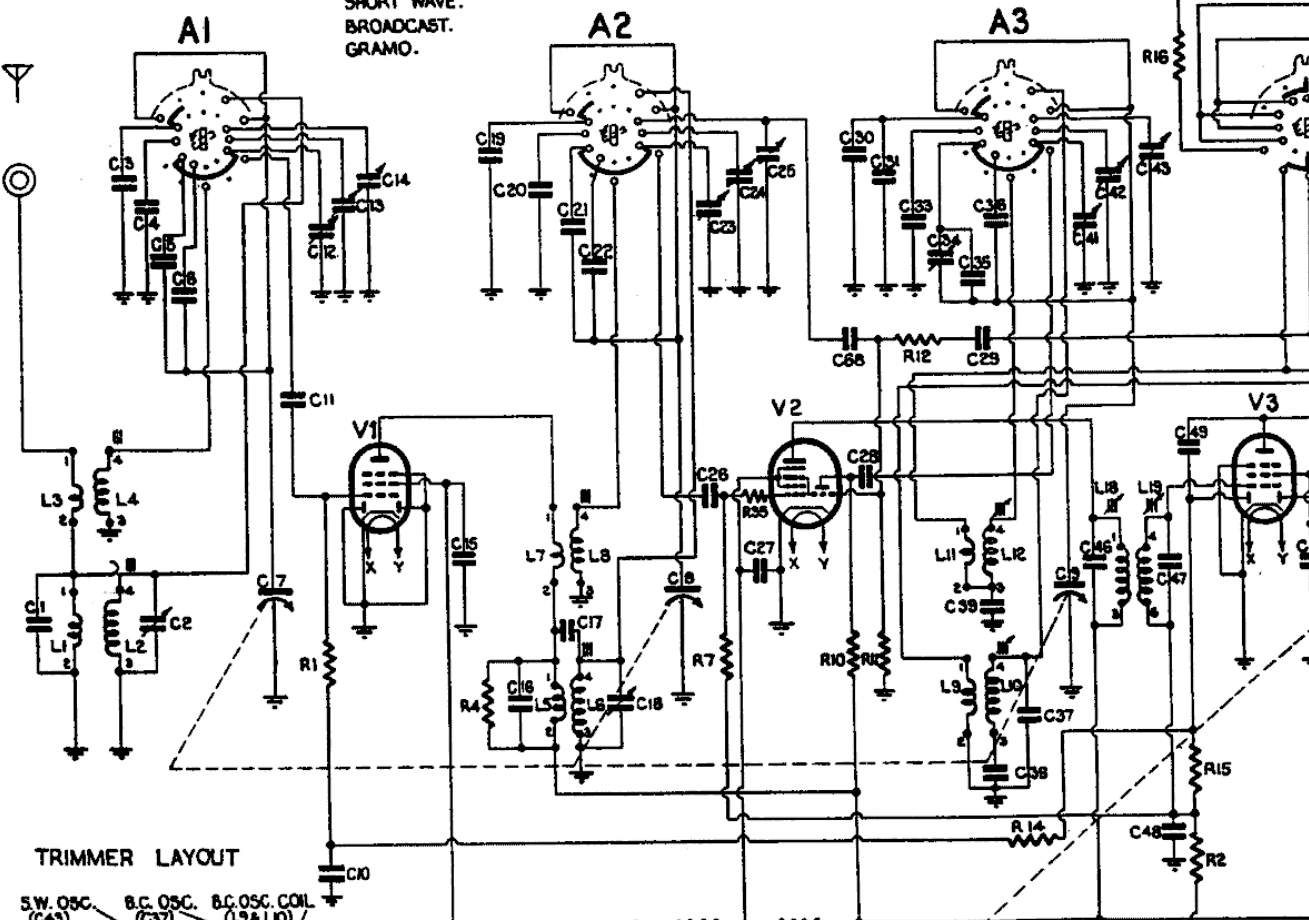
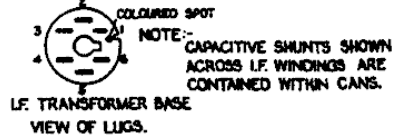
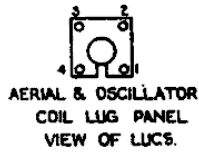

TRIMMER LAYOUT

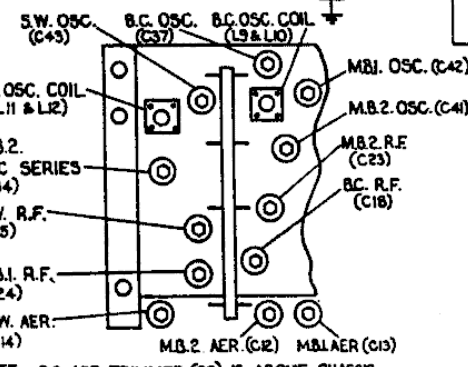

NOTE:- B.C. AER. TRIMMER (C2) IS ABOVE CHASSIS

13, 14, 15, 16, 17, 18, 19, 20, 21, 22, 23, 24	15, 19,	17	20, 21,	22, 23,	24	L
25, 26, 27, 28, 29, 30, 31, 32, 33, 34, 35, 36, 37, 38, 39, 40, 41, 42, 43, 44, 45, 46, 47, 48, 49	50,	51, 45, 54,	52, 53,	56,	59	C
10, 11, 12	14	5, 6, 16, 15, 2,	17, 13, 18, 19	20, 22, 21,	23, 24, 25, 27, 28, 30, 31, 29	R
11, 12, 13	3				5,	V

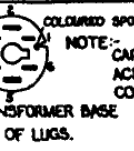

SWITCH B1. SHOWN IN
OFF POSITION.
POSITIONS : OFF,
ON, QUALITY
SPEECH
MELLOW
DEEP

